

**Series 6, washing machine, front loader, 10 kg, 1400 rpm
WGG254FTSN**



Perfect results at the minimum detergent and water consumption thanks to i-DOS automatic dosing and ActiveWater Plus.

- **i-DOS:** Automatically measures the precise amount of detergent and water needed.
- **Iron Assist:** reduce wrinkles up to 50%.¹
- **Best energy class A:** save energy with the most efficient class A.
- **Active Water Plus:** For highly efficient use of water even with smaller loads thanks to automatic load detection.
- **Speed Perfect:** perfectly clean in up to 65% less time.²

Technical Data

Built-in / Free-standing:	Free-standing
Door hinge:	Left
Color / Material body:	White
Length electrical supply cord:	210 cm
Height of the appliance:	845 mm
Dimensions of the product:	845x598x588 mm
Wheels:	No
Net weight:	75.3 kg
Drum volume:	70 l
Door Frame:	White
Noise level washing:	52 dB(A) re 1pW
Connection rating:	2300 W
Fuse protection:	10 A
Voltage:	220-240 V
Frequency:	50 Hz
Energy Star Qualified:	No
Cord Included:	Yes
Length of supply hose (in):	59.05 "
Dimensions of the packed product:	34.25 x 25.59 x 26.77
Net weight:	166.000 lbs
Gross weight:	168.000 lbs
Length of drain hose:	150.00 cm
Length of supply hose:	150.00 cm
Dimensions of the packed product (HxWxD):	870 x 650 x 680 mm
Gross weight:	76.3 kg
Connection rating:	2300 W
Fuse protection:	10 A
Voltage:	220-240 V
Frequency:	50 Hz
Water protection system:	Multiple water protection
Maximum spin speed:	1400 rpm
Spin speed options:	Variable
Digital countdown indicator:	Yes
Drying progress indicator:	LED-display, LED
Energy Efficiency Class (Regulation (EU) 2017/1369):	A
Weighted energy consumption in kWh per 100 washing cycles of eco 40-60 programme (EU 2017/1369):	51 kWh
Rated capacity, in kg, for the eco programme at full load (EU 2017/1369):	10.0 kg
The water consumption of the eco programme in liters per cycle (EU 2017/1369):	50 l
Duration of eco 40-60 programme in hours and mins at rated capacity (EU 2017/1369):	3:50 h
Spin-drying efficiency class of eco 40-60 programme (EU 2017/1369):	B
Airborne acoustical noise emission class (EU 2017/1369):	B
Airborne acoustical noise emissions (EU 2017/1369):	74 dB(A) re 1pW

Optional accessories

WMZ2200	Floor securing component
WMZ2381	Extension for cold water inlet /Aquastop
WMZMPF10	Microplastic Filter
WMZPW20W	Platform with pull-out, washer, cubic

¹ Test No. E-0323-PT-22 of the Deutschen Institute für Textil- und Faserforschung Denkendorf (DITF) of 12.07.22, related to the crease reduction of commercial cotton garments (T-shirts and shirts) in the Iron Assist program according to DIN EN ISO 15487 in comparison to textiles not treated with Iron Assist.

² Difference between the duration of Easy Care Programme 40°C and the duration of Easy Care Programme 40°C in combination with Speed Perfect option.

Series 6, washing machine, front loader, 10 kg, 1400 rpm WGG254FTSN

Perfect results at the minimum detergent and water consumption thanks to i-DOS automatic dosing and ActiveWater Plus.

Engine power and consumption

- Energy Efficiency Class¹: A
- Energy² / Water³: 51 kWh / 50 litres
- Load capacity: 1 - 10 kg
- Spin drying efficiency class: B
- Spin power / spin speed^{**}: 400 - 1400 t/min
- Noise level: 74 dB (A) re 1 pW
- Noise efficiency class: B

Programmes

- standard programmes: cottons, easy care, delicate, wool hand wash
- automatic programme: sensorcontrolled washing and dosage
- Iron Assist: Steam programme that reduces wrinkles on dry clothes
- Special programmes: automatic gentle, Drum clean with reminder, Spin / Drain, quick/mixture, sportswear, Rinse, Quick 30'/15'

Options

- SpeedPerfect: perfectly clean in up to 65% less time. ***
- i-DOS: automatic dosing of liquid detergent and softener
- 4 stain removal options at the touch of a button
- TouchControl buttons: Reduced Ironing, Ready in, Stain selection, i-DOS, start/pause with reload function, Temperature, SpeedPerfect, Prewash, Spin speed reduction/Rinse hold
- Reload function / pause function

Comfort and safety

- i-Dos: intelligent dosage system, Self cleaning detergent drawer, From front
- Reload function: Be flexible in adding laundry items even after start of the wash cycle.
- Large LED-Display for programme status indication, temperature selection, max. spin speed, remaining time and 24 h end time delay and load recommendation
- Hygiene Plus: clean laundry and killing germs effectively
- XXL Drum volume: 70 l
- Usage meter: counts completed programmes
- Drumlight: Drum interior light: LED
- VarioDrum: gentle and efficient washing
- DrumClean with reminder function
- 47 cm porthole, white with 160° opening door
- ActiveWater Plus: for highly efficient use of water even with small loads thanks to automatic load detection.
- demo programme, Stain-automatic
- AntiVibration Design: more stability and quietness
- 3G-Sensor, Circulatory sensor for optimal wateruse, Motor load detection, AquaSensor for optimum rinse results
- soft dial
- Electronic childlock
- Buzzer

Technical information:

- EcoSilence Drive: quiet motor with long lifetime
- 10 years guaranty on EcoSilence Drive
- Multiple water protection
- Foam detection system
- Out of balance load adjustment
- slide-under at hight of 85 cm
- Dimensions (H x W): 84.5 cm x 59.8 cm
- Appliance depth: 58.8 cm
- Appliance depth incl. door: 63.2 cm
- Appliance depth with open door: 104.9 cm

¹ Scale of Energy Efficiency Classes from A to G

² Energy consumption in kWh per 100 cycles (in programme Eco 40-60)

³ Weighted water consumption in litres per cycle (in programme Eco 40-60)

⁴ Duration of programme Eco 40-60

** Values are rounded.

*** Comparison between the program duration of Easy-care 40°C and the program duration of Easy-care 40°C + activated Speed option

**Series 6, washing machine, front
loader, 10 kg, 1400 rpm
WGG254FTSN**

Measurements in mm

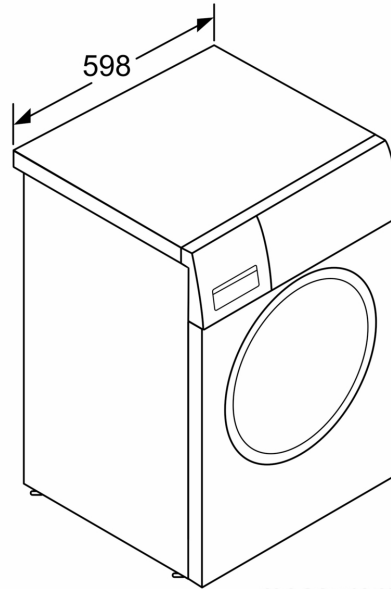
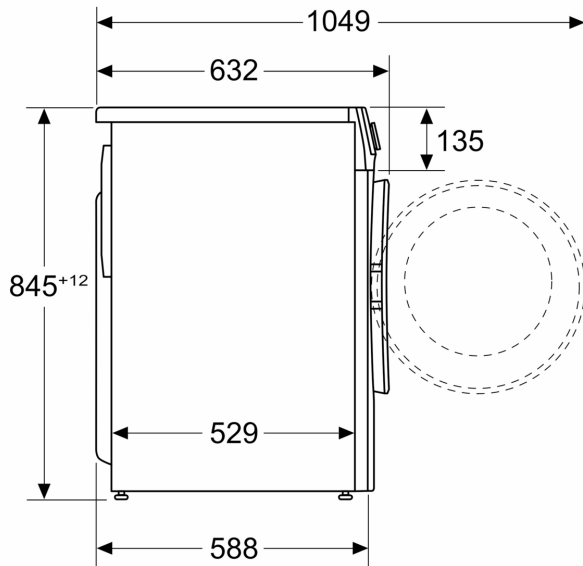

measurements in mm